

## NextLink - Repeater Model

### Solar-Powered Connectivity

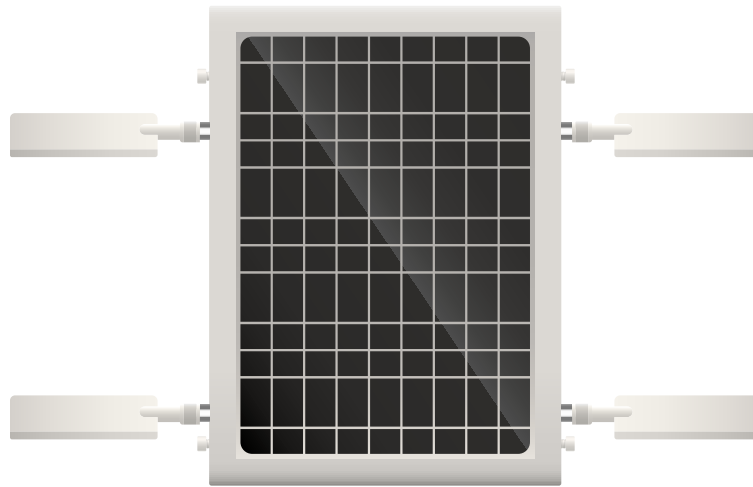

The NextLink (NL4) is the ultimate all-in-one solar-powered Repeater. Featuring the fastest charging and longest-lasting battery in its class, the NextLink ensures seamless connectivity with the simplest deployment.

### Flexible Deployment

Recognizing the critical need for reliable connections, especially in areas with limited power and network access, we have designed the NextLink to integrate effortlessly into diverse environments.

The NextLink's all-in-one design combines an efficient solar panel, high-capacity battery, and powerful radios, enabling installation virtually anywhere –regardless of wired power or network availability.

### Extending Communication

NextLinks work seamlessly together to extend your wireless meter network even into areas outside of cellular coverage.

Powerful external antennas ensure reliable communication for meter points spread over long-distances as well as in high-density submetering applications.

### Sustainable Longevity

Built with a robust cast-aluminum housing and fully waterproof design, the NextLink is engineered to withstand even the harshest conditions. Through rain or shine, NextLink delivers connectivity using renewable solar power, making it both a practical and eco-friendly fixed-wireless solution.

### Key Benefits

- Built-in 5G LTE cellular
- Operates as a Repeater to expand coverage
- Fully recharges with only 6 hours of full sunlight
- Efficient power management provides up to 7 days of operation with no-light
- 2-way meter communication
- High-gain external antennas for extended range
- Battery will continue to charge in freezing temperatures
- IP-68 rated for outdoor use
- All-in-one unit eliminates the headaches and issues associated with piecemeal kits

### Warranty

- 7-year standard warranty

# Specifications & Installation Guide



## Specifications

### Dimensions

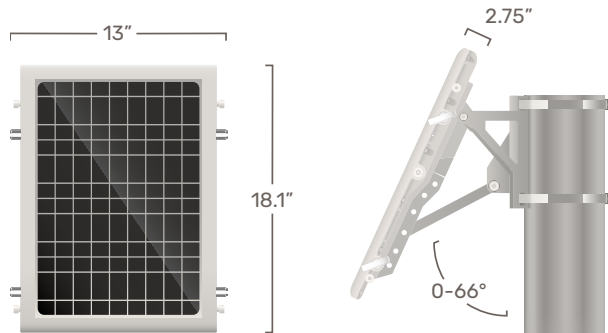

### Approvals

- FCC ID: 2A8EC-NL4
- IC ID: 28950-NL4
- Contains FCC ID: 2ANP000NRF9151
- Contains IC ID: 24529-NRF9151

### Communications

- 5G LTE cellular with simple no-contract subscription
- Easy mobile app configuration
- Built-in NextConnect receiver for meter communication
- Seamlessly operates as a relay to extend network

### Data

- AMI solution, continuous meter communication
- Mobile and web access for configuration and monitoring
- Supports detailed utility usage history

### Power

- Solar-powered, integrated 15W panel
- Built-in ESD protection for lightning protection
- High capacity rechargeable battery
- Supports operation through extended low-light weather
- Field-replaceable battery

### Temperature

Operation from -40°F to 140°F | -40°C to 60°C

### Environment

- Engineered for long-term outdoor durability
- Compact design, industrial quality cast aluminum
- Weather-resistant construction, IP-68 rated
- Designed to withstand strong winds and harsh conditions

### Installations

- Accessories included for pole, wall, or roof mounting
- Mobile app guides optimal solar panel positioning
- Simple LED status feedback

### Warranty

Next Meters warrants the NL4 to be free from defects in materials and workmanship for a period of seven years from date of manufacture when installed in accordance with these instructions and with limitations as detailed in the complete warranty.

[docs.nextmeters.com/warranty](https://docs.nextmeters.com/warranty)

Due to continuous product improvement and the need to comply with evolving regulations, Next Meters reserves the right to modify product specifications without prior notice.

### Contact

For additional information or assistance, please visit our Support Center or contact our Product Support Team:

[support.nextmeters.com](https://support.nextmeters.com)

(844) 538-8203 | [support@nextmeters.com](mailto:support@nextmeters.com)



# Specifications & Installation Guide

## Installation

### Full Package Contents

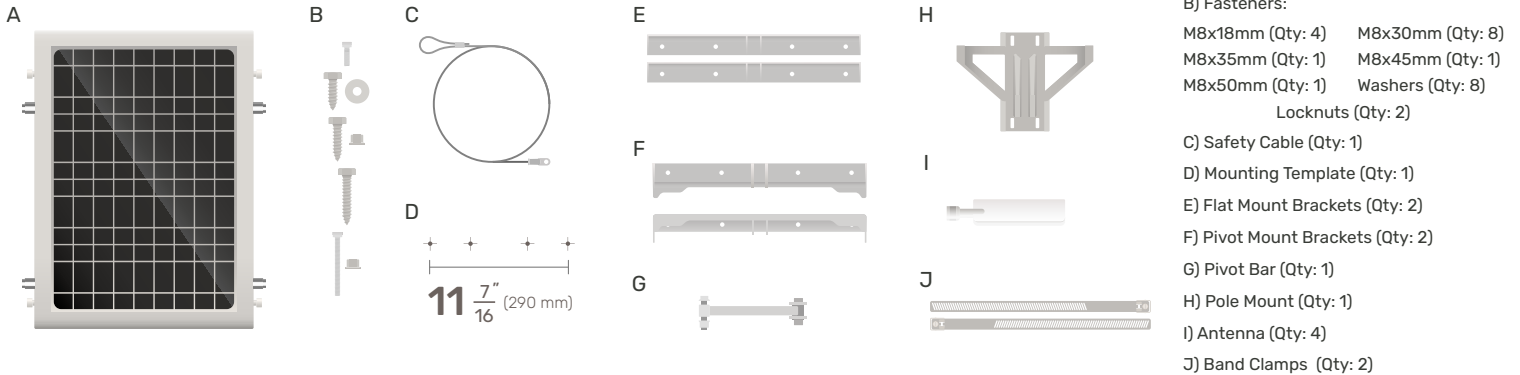

### Qualifying Installations

The NextLink should be installed in an orientation and location that maximizes the solar panel's ability to charge the device.

Choose a location with clear lines of sight to the sky year-round. When using a mount that allows you to adjust the angle, choose an angle that will allow the panel to face the sun directly at midday.

Where possible, the NextLink should be installed no less than 10 feet (3 meters) from the ground. Higher installations are generally preferred. Use a stable ladder when necessary. Take appropriate safety precautions.

For latitudes that experience significant variations in the position of the sun between seasons, you should angle the panel to face where the sun would be in the winter.

In locations where snow is expected, flat mounting is not recommended. The buildup of snow on the solar panel will disrupt device charging.

The NextLink mounting systems are designed to withstand significant environmental pressures. However, it is vital to complete the installation process, **including the installation of the safety cable**, to ensure protection of persons and property in the event of mounting system failure caused by extreme weather.

Failure to follow these instructions may cause you to forfeit the protections guaranteed in our warranty.

### Required Tools

To install the NextLink, you will need the following:



Drill with 1/4" Drill Bit



Pencil



Adjustable Wrench

### Mounting Options

NextLink can be mounted three ways: Wall Pivot, Pole, or Flat Mount. All required hardware (besides tools) for each option is included in the box.

### Installation: Wall Pivot Mount

Using the pivot mount side of the included drilling template, mark the holes for the mounting hardware on the surface where the device will be mounted.

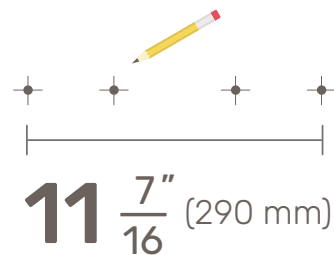

Drill the holes using a 1/4" drill bit.

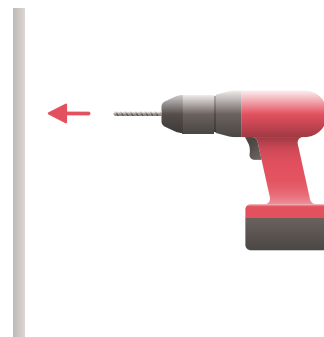

# Specifications & Installation Guide



## Installation (cont.)

Using the holes drilled in the last step, attach the brackets to the surface using eight (8) M8x30mm lag bolts and washers. You will use four (4) bolts/washers per bracket.

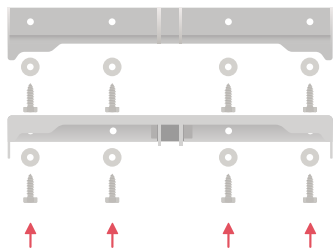

Attach the top of the NextLink to the top mount bracket using two (2) M8x18mm socket head cap screws. At this stage, these screws should be hand tightened.

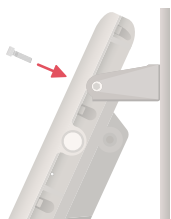

Attach one end of the pivot bar to the center mounting location of the lower mount bracket using the M8x35mm bolt and an M8 locknut. At this stage, these fasteners should only be hand tightened.

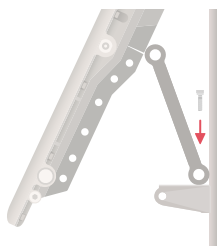

Attach the opposite end of the pivot bar to the NextLink. Choose the appropriate set of holes in the center of the NextLink to optimize the angle of the solar panel (relative to the sun). Use the M8x45mm bolt and M8 locknut.

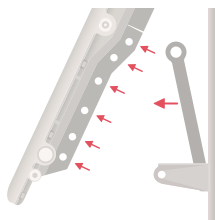

Once the appropriate angle is achieved, use a wrench to tighten all bolts connecting the NextLink and mounting hardware well beyond hand tight to ensure a secure connection. Do not use excessive force, which can result in over-tightening.

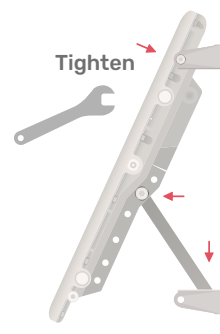

Attach the safety cable to a solid mounting point near the NextLink. Then remove one of the M8x18mm screws and use it to bolt the end of the safety cable to the mount bracket and the NextLink.

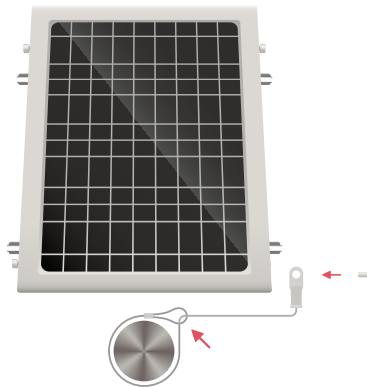

Attach the antennas by hand tightening them to the connection points on the sides of the NextLink. Any antenna can be connected to any connection point.

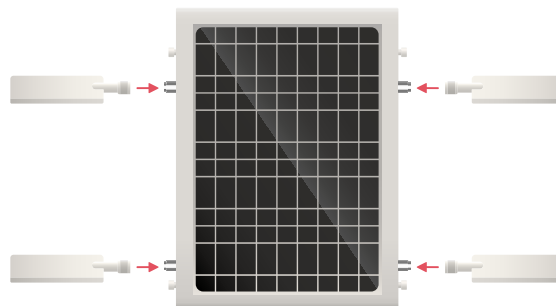

Proceed to programming instructions on page 8.



## Installation (cont.)

### Installation: Pole Mount

*Note: It is recommended that two people work together to complete pole mount installations.*

Hook the arms of the pole mount into the ears of the NextLink.

Loosely attach the arms to the ears with two (2) M8x18mm screws.

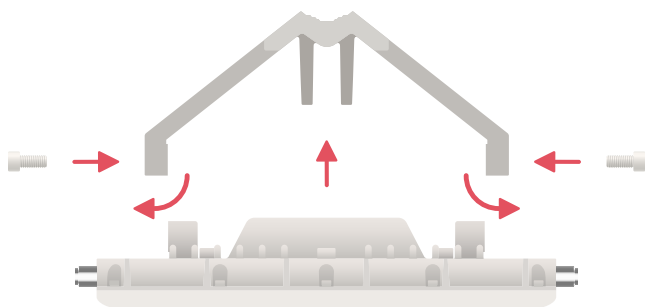

Attach one end of the pivot bar to the pole mount using the M8x50mm bolt and M8 locknut (see item A in the illustration below).

Attach the opposite end of the pivot bar to the NextLink (see item B in the illustration below). Choose the appropriate set of holes in the center of the NextLink to optimize the angle of the solar panel (relative to the sun). Use the M8x45mm bolt and M8 locknut.

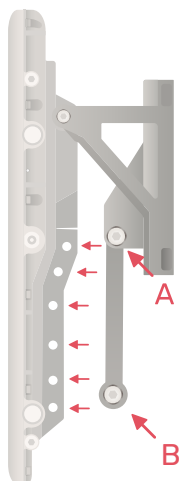

Once the appropriate angle is achieved, use a wrench to tighten all bolts connecting the NextLink and mounting hardware well beyond hand tight to ensure a secure connection. Do not use excessive force, which can result in over-tightening.

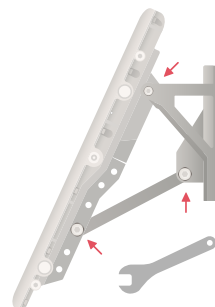

To connect pole mount to the pole, slide the band clamps through the slots at the top and bottom of the pole mount, then around the pole.

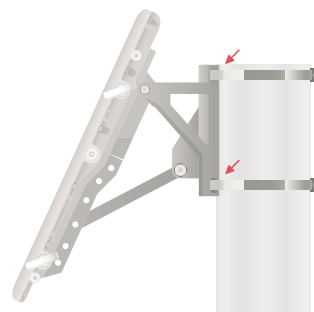

Fasten the band clamps around the pole. One person should hold the NextLink in place as the other tightens the band clamps around the pole.

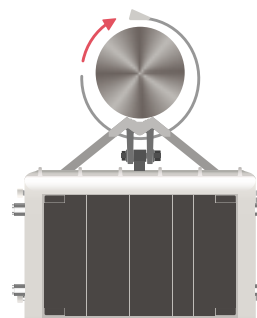

**Important:** Install the band clamps to no more than 18 lbs of torque. Do not overtighten. Do not use an impact driver to tighten. Overtightening can compromise installation integrity.



## Installation (cont.)

Attach the safety cable to a solid mounting point near the NextLink. Then remove one of the M8x18mm screws and use it to bolt the end of the safety cable to the mount bracket and the NextLink.

If no solid mounting point is available, you can loop the safety cable around the pole before securing it to the NextLink.

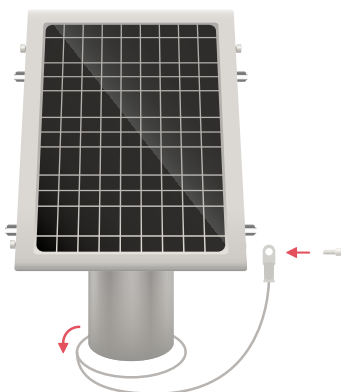

Attach the antennas by hand tightening them to the connection points on the sides of the NextLink. Any antenna can be connected to any connection point.

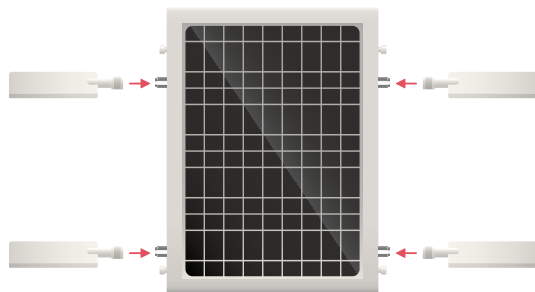

Proceed to programming instructions on page 8.

## Installation: Flat Mount

Using the flat mount side of the included drilling template, mark the holes for the mounting hardware on the surface where the device will be mounted.

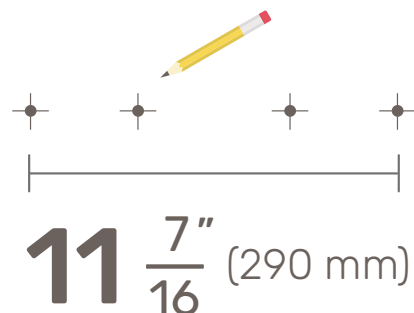

Drill the holes using a 1/4" drill bit.

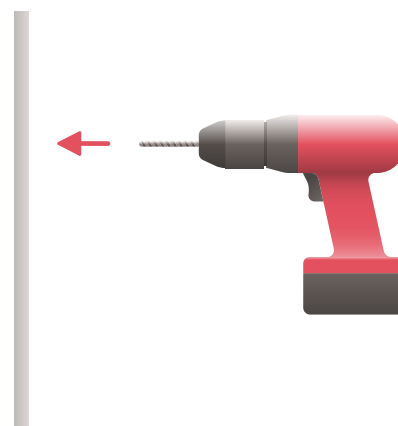

Using the holes drilled in the previous step, attach the brackets to the surface using eight (8) M8x30mm lag bolts and washers. You will use four (4) bolts/washers per bracket.

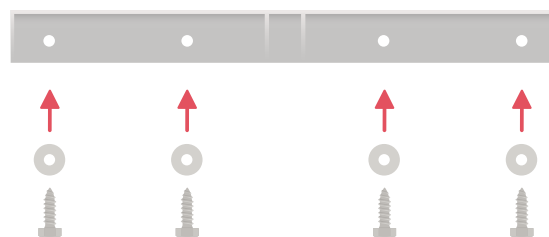



## Installation (cont.)

Attach the NextLink to the mounts using four (4) M8x18mm socket head cap screws.

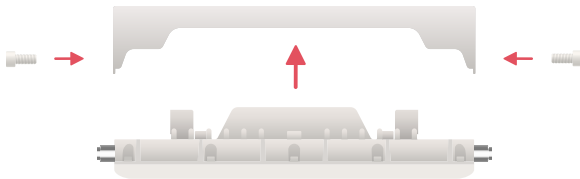

Attach the safety cable to a solid mounting point near the NextLink. Depending on your installation location, you may need to loop the cable through itself around a mounting point.

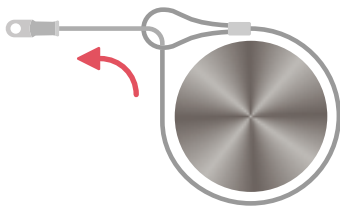

Remove one of the M8x18mm screws and use it to bolt the end of the safety cable to the mount bracket and the NextLink.

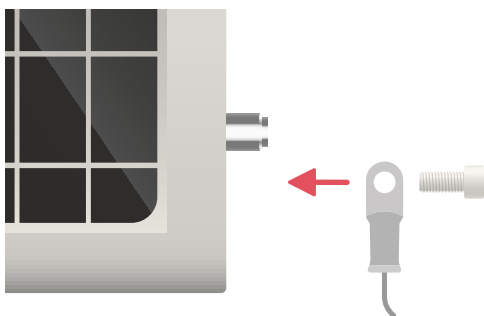

Attach the antennas by hand tightening them to the connection points on the sides of the NextLink. Any antenna can be connected to any connection point.

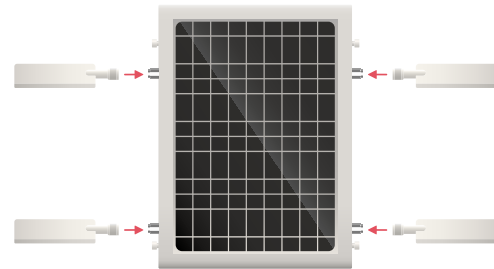

Proceed to programming instructions on page 8.

# Specifications & Installation Guide



## Programming

### Programming & Verification

Programming is the process of associating the NextLink's serial number with property where it is installed. This ensures it can communicate with the NextCentury Cloud.

This process can be completed before or after installation using the NextCentury (NCSS) mobile app or on the web platform (app.nextcenturymeters.com).



After logging in to the app or web platform, select or create the property that corresponds to the NextLink.

On the mobile app, tap "View Repeaters", then tap the "+" icon.

On the web platform, select "Equipment", then "Network" (located in the top right corner).

Program the NextLink by entering its serial number. You can also scan the device barcode (located on the back of the NextLink) using the barcode scanner in the mobile app.

Wave a magnet below the antenna on the upper right-hand side to verify communication with the network. Two green LED blinks indicate successful connectivity.

If no confirmation is received, relocate the NextLink or add additional NextLinks as needed.

### LED Status Information

You can check the NextLink's current battery status by viewing the LED on the device. When a magnet is held by the device's battery indicator LED (located just below the antenna on the upper right-hand side of the device), it will light up to indicate the device's current battery.

 **FULL BATTERY**

 **LOW BATTERY**

 **VERY LOW** (Radios are turned off)

Current battery levels can also be checked in the NCSS mobile app or on the NextCentury web platform.

### Long-Term Battery Information

The NextLink's field-replaceable battery has a lifespan of 7-10 years. You will receive alerts within the NCSS app starting several months before the battery needs to be replaced.



## Television and Radio Interference

### Television and Radio Interference

**FCC Statement:** This equipment has been tested and found to comply with the limits for a Class B digital device, pursuant to part 15 of the FCC Rules. These limits are designed to provide reasonable protection against harmful interference in a residential installation.

This equipment generates, uses and can radiate radio frequency energy and, if not installed and used in accordance with the instructions, may cause harmful interference to radio communications. However, there is no guarantee that interference will not occur in a particular installation.

If this equipment does cause harmful interference to radio or television reception, which can be determined by turning the equipment off and on, the user is encouraged to try to correct the interference by one or more of the following measures:

- Reorient or relocate the receiving antenna.
- Increase the separation between the equipment and receiver.
- Connect the equipment into an outlet on a circuit different from that to which the receiver is connected.
- Consult the dealer or an experienced radio/TV technician for help.

**FCC Radiation Exposure Statement:** This equipment complies with FCC radiation exposure limits set forth for an uncontrolled environment. This equipment should be installed and operated with minimum distance 40cm between the radiator and your body.

**ISED Statement:** This radio transmitter 28950-NL4 has been approved by ISED to operate with the antenna types listed below with the maximum permissible gain indicated. Antenna types not included in this list, having a gain greater than the maximum gain indicated for that type, are strictly prohibited for use with this device.

Included external antenna:

- Type: DiPole
- 698-824MHz: Gain of 2.19dBi
- 824-960MHz: Gain of 2.20dBi
- 1710-2200MHz: Gain of 3.8dBi

This device complies with Innovation, Science and Economic Development Canada's licence-exempt RSSs. Operation is subject to the following two conditions:

- (1) This device may not cause interference; and
- (2) This device must accept any interference, including interference that may cause undesired operation of the device.

**ISED Radiation Exposure Statement:** This equipment complies with the ISED RSS-102 radiation exposure limits set forth for an uncontrolled environment. This equipment should be installed and operated with a minimum distance of 40cm between the radiator and your body.

### Television and Radio Interference (French)

Déclaration d'ISDE: Cet émetteur radio 28950-NL4 a été approuvé par ISDE pour fonctionner avec les types d'antennes énumérés ci-dessous, avec le gain maximal autorisé indiqué. Les types d'antennes non inclus dans cette liste, dont le gain est supérieur au gain maximal indiqué pour ce type, sont strictement interdits avec cet appareil.

Antenne externe incluse:

- Type : Dipôle
- 698-824 MHz : Gain de 2,19 dBi
- 824-960 MHz : Gain de 2,20 dBi
- 1 710-2 200 MHz : Gain de 3,8 dBi

Cet appareil est conforme aux CNR d'Innovation, Sciences et Développement économique Canada (Innovation, Sciences et Développement économique Canada) applicables aux appareils exemptés de licence. Son utilisation est soumise aux deux conditions suivantes:

- (1) Cet appareil ne doit pas causer d'interférences; et
- (2) Cet appareil doit tolérer toute interférence, y compris celles qui pourraient nuire à son bon fonctionnement.

Déclaration d'ISDE relative à l'exposition aux rayonnements: Cet équipement est conforme aux limites d'exposition aux rayonnements du CNR-102 d'ISDE, établies pour un environnement non contrôlé. Cet équipement doit être installé et utilisé en maintenant une distance minimale de 40 cm entre le radiateur et votre corps.